

Ref. **8275**

PORTA-PLAQUITAS RANURADO S90SN12

S90SN12 Side & Face Milling Tool-Holder
Porte-Plaquettes rainurado S90SN12

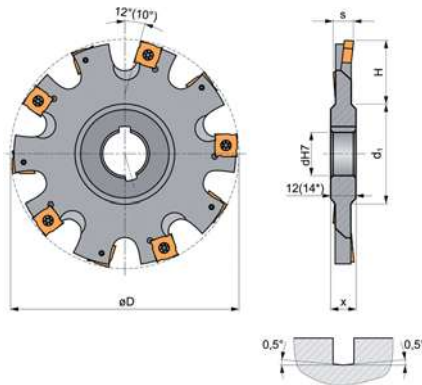

γ_p	-0°30'	K_r	90°
γ_f	+2°30'	$a_{p,max}$	H

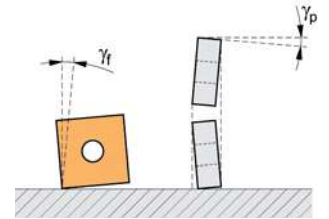

ISO	D	dH7	H	s	d ₁	Z	Plaquita Insert Plaquette	N° Art.	€		
S90-100-06	100	27	25	6	41	10	SNH.-1203..	20840	897,07	Ref. 8804 Z-745 Art. 21315 3,61 € 5	Ref. 8801 1
S90-125-06	125	32	40	6	48	12	SNH.-1203..	20869	1.020,67		
S90-160-06	160	40	44	6	58	16	SNH.-1203..	20873	1.216,51		
S90-100-08	100	27	25	8	41	10	SNH.-1204..	20855	897,07	Z-846 Art. 21364 3,61 € 5	ZT-15 Art. 10512 11,06 €
S90-125-08	125	32	40	8	48	12	SNH.-1204..	20870	1.020,67		
S90-160-08	160	40	44	8	58	16	SNH.-1204..	20874	1.216,51		
S90-100-10	100	27	25	10	41	10	SNH.-1205..	20858	897,07	Z-845 Art. 21349 3,61 € 5	5
S90-125-10	125	32	40	10	48	12	SNH.-1205..	20871	1.020,67		
S90-160-10	160	40	44	10	58	16	SNH.-1205..	20876	1.216,51		
S90-100-12	100	27	25	12	41	10	SNH.-1207..	20867	897,07	Z-847 Art. 21365 4,05 € 5	5
S90-125-12	125	32	40	12	48	12	SNH.-1207..	20872	1.020,67		
S90-160-12	160	40	44	12	58	16	SNH.-1207..	20877	1.216,51		

Tipo Mecanizado Machining Type - Type d'Usinage		



	Tornillo - Screw - Vis
	Destornillador Screwdriver Tournevis

Plaquita / Insert / Plaquette: **Plaquette: Pag. 632**



SNHQ

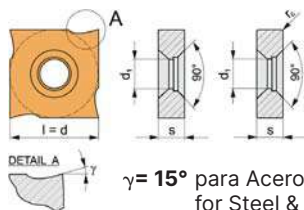

$\gamma = 15^\circ$ para Acero y Fundición
for Steel & Cast Iron
Pour acier et fonte

Calidades
Qualities
Qualités

Dimensiones
Dimensions

ISO	P-640	l	s	d ₁
SNHQ 1203AZTN	●	12,70	3,20	5
SNHQ 1204AZTN	●	12,70	4,50	5
SNHQ 1205AZTN	●	12,70	5,40	5
SNHQ 1207AZTN	●	12,70	7,00	5

Plaquita / Insert / Plaquette: **Pag. 632**

Geometría Geometry Géométrie	Foto Picture Photo	Grupo Materiales Pieza Trabajo Workpiece Material Group Groupe matériaux pièce travail
SNHQ		Fresado Milling Fraisage
		Acabado Finishing Finition
		Desb. Medio Roug. & Finish. Semi-Finition
		Desb. Grueso Coarse Rough. Ébauche

P	M	K	S	N	H
---	---	---	---	---	---

Condiciones Corte
Cutting Conditions
Conditions coupe

f_z 0,20-0,50 mm/z

