

Ref. **9674**

FRESA RANURADO ALUCOBOND / DIBOND

Alucobond / Dibond Sheet Bending End Mill

Fraise rainurage Alucobond/Dibond

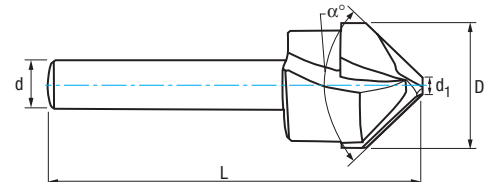

MD HM Carbure	IZAR std.		12000- 15000 rpm	Vf: 400-600 mm/min
----------------------------	--------------	--	---------------------	-----------------------

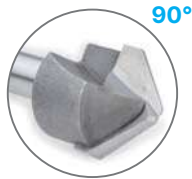

90°



135°

D mm	d mm	L mm	d ₁ mm	α °	N° Art. MD/HM	€
α=90°						
16	8	59	2,5	90	81516	51,56
18	8	59	2,5	90	81519	52,29
20	8	59	2,5	90	81520	53,72

D mm	d mm	L mm	d ₁ mm	α °	N° Art. MD/HM	€
α=135°						
16	8	59	2,3	135	81521	51,56
18	8	59	2,3	135	81522	52,29
20	8	59	2,3	135	81523	53,72

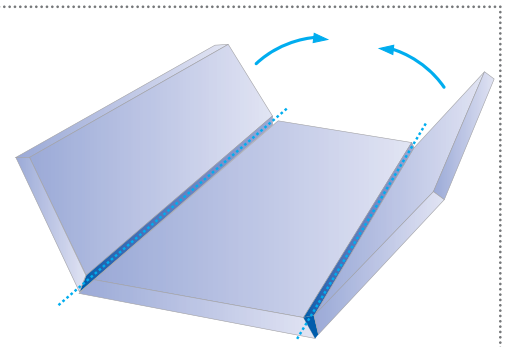
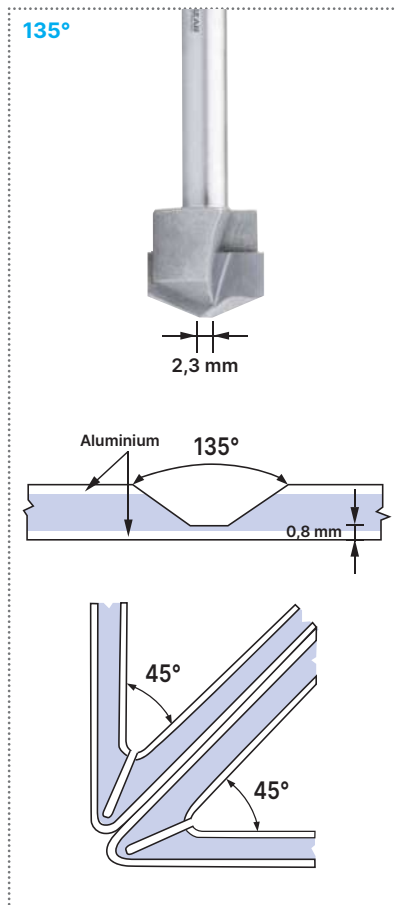
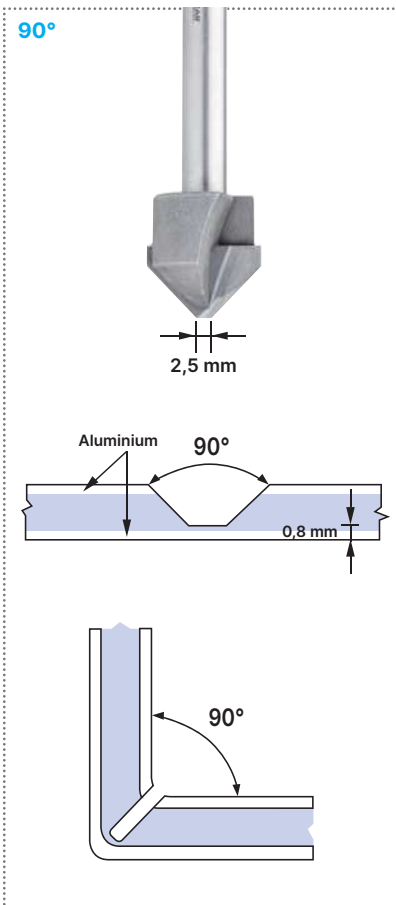

- Fresa especial para ranurados en Alucobond, Dibond, Durabond, Alupanel, Plexiglas, Alpolic, ACP, ACM...
- Se recomienda cortar casi hasta el fondo para poder doblar las planchas fácilmente.

- Special end mill for bending sheets of Alucobond, Dibond, Durabond, Alupanel, Plexiglas, Alpolic, ACP, ACM...
- The material should be cut almost until the bottom part leaving little amount of material left, that way the sheet will be bended easily.

- Fraise spécial pour rainurage sur Alucobond, Dibond, Durabond, Alupanel, Plexiglas, Alpolic, ACP, ACM...
- Il est recommandé de couper presque jusqu'au fond pour pouvoir plier les plaques facilement.

